

“L” Style Compact Vacuum Filters

CSL Series 3/8” - 4”

Benefits

- Large dirt holding capacity and easy field cleaning, especially when mounted horizontally or inverted
- Low pressure design

Features

- Seamless drawn housings
- O-ring seal
- Corrosive resistant black powder coat carbon steel
- Stainless steel torsion clips for durability

Technical Specifications

- Vacuum Rating: medium vacuum service*
- Temp (continuous): min -26°C (-15°F) max 104°C (220°F)
- Filter change out differential: 37-50 mbar over initial ΔP
- Polyester: 99%+ removal efficiency standard to 5 micron
- Paper: 99%+ removal efficiency standard to 2 micron

Options



- Vacuum gauge
- Higher holding capacity configurations available (select models)
- Material/Finishes: stainless steel, epoxy coating
- Support brackets
- Alternative top-to-canister fastening system for low pressure or pulsating systems
- Stainless steel (select models)



CSL Series 3/8" - 4"

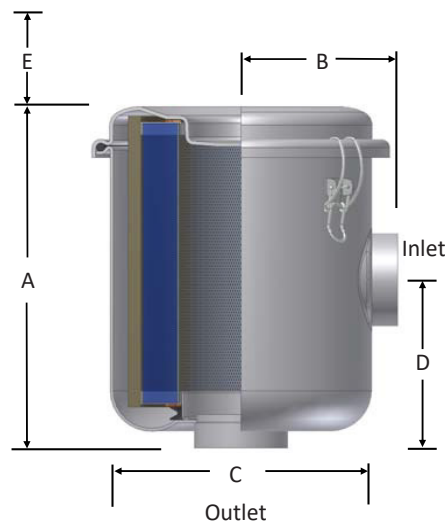

Inlet/Outlet Size	Type	Assembly m ³ /hr Rating	Assembly Part Number		Dimensions - mm				Suggested Service Ht. E	Approx. Weight (kg)	Replacement Element Part No.		Element m ³ /hr Rating
			Polyester	Paper	A	B	C	D			Polyester	Paper	
3/8"	BSPP	31	CSL-825-039HCB	CSL-824-039HCB	85	54	95	46	76	0.40	825	824	43
1/2"	BSPP	31	CSL-825-051HCB	CSL-824-051HCB	89	57	95	49	76	0.40	825	824	43
1/2"	BSPP	34	CSL-843-051HCB	CSL-842-051HCB	103	76	146	64	83	1.4	843	842	94
3/4"	BSPP	41	CSL-825-076HCB	CSL-824-076HCB	89	58	95	50	76	0.40	825	824	43
3/4"	BSPP	43	CSL-843-076HCB	CSL-842-076HCB	103	76	146	64	83	1.4	843	842	94
1"	BSPP	60	CSL-843-101HCB	CSL-842-101HCB	111	83	146	67	83	1.4	843	842	94
1"	BSPP	68	CSL-849-101HCB	CSL-848-101HCB	170	105	187	114	133	2.3	849	848	196
1 1/4"	BSPP	94	CSL-843-126HCB	CSL-842-126HCB	111	83	146	67	83	1.4	843	842	94
1 1/4"	BSPP	102	CSL-849-126HCB	CSL-848-126HCB	170	105	187	114	133	2.3	849	848	196
1 1/2"	BSPP	136	CSL-849-151HCB	CSL-848-151HCB	171	105	187	114	133	2.3	849	848	196
2"	BSPP	298	CSL-851-201HCB	CSL-850-201HCB	260	114	222	127	235	6.8	851	850	493
2 1/2"	BSPP	357	CSL-851-251HCB	CSL-850-251HCB	271	130	222	140	235	6.8	851	850	493
3"	BSPP	510	CSL-239-301HCB	CSL-238-301HCB	362	184	337	182	279	15	239	238	969
3"	NPT	510	CSL-2541-301B	CSL-2540-301B	391	216	337	216	305	14	2541	2540	1360
4"	NPT	880	CSL-2541-401B	CSL-2540-401B	416	242	337	241	305	15	2541	2540	1360

*See Vacuum Filter Technical Data for Vacuum Service Data.



SOLBERG®

All model offerings and design parameters are subject to change without prior notice.
Contact your representative or Solberg for the most current information.

“L” Style Vacuum Filters

CSL Series 3” - 6” BSPT, DN80 - DN300 FLG

Benefits

- Reduce piping costs with multiple mounting configurations (mount horizontal or inverted)
- Minimize equipment pressure-drop change with low pressure-drop filter design

Features

- Heavy duty T bolts for easy maintenance
- Corrosive resistant carbon steel construction
- Black powder coat finish
- O-ring stays in place with unique U-channel groove
- Inlet & outlet 1/4” gauge taps
- Lifting lugs
- Brackets for optional support legs
- Nameplate bracket

Technical Specifications

- Vacuum Rating: Medium vacuum service*
- Filter change out differential: 37-50 mbar over initial ΔP
- Polyester: 99%+ removal efficiency standard to 5 micron
- Paper: 99%+ removal efficiency standard to 2 micron

*See Vacuum Filter Technical Data for vacuum service data.

Options



- Straight-through configurations
- Various filter media
- Stainless steel
- Various nonstandard finishes and connection styles
- ISO Flange
- PN6, PN16 flange patterns
- Flange faces free of paint
- Mounting housing bands
- Internal surfaces free of paint

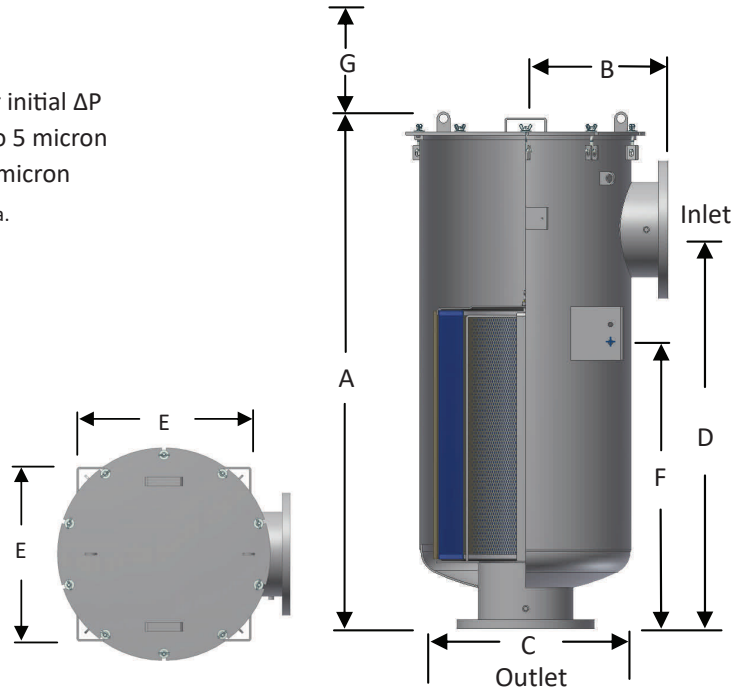
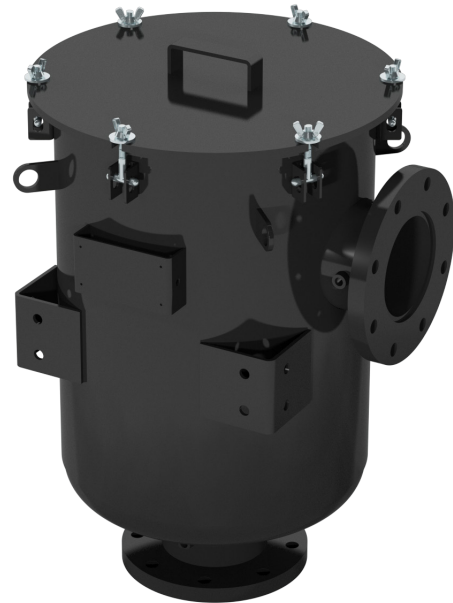

CSL Series 3" - 6" BSPT, DN80 - DN300 FLG

Flanged Assemblies

Flange Inlet & Outlet	Assembly m ³ /hr Rating	Assembly Part Number		Dimensions - mm						Suggested Service Ht. G	Approx. Weight kg	Replacement Element Part No.		Element m ³ /hr Rating
		Polyester	Paper	A	B	C	D	E	F			Polyester	Paper	
DN80	510	CSL-235P-DN80	CSL-234P-DN80	695	229	356	470	300	312	305	28	235P	234P	970
DN80	510	CSL-335P-DN80	CSL-334P-DN80	695	229	356	470	300	312	432	29	335P	334P	1360
DN100	885	CSL-235P-DN100	CSL-234P-DN100	695	229	356	470	300	312	305	28	235P	234P	970
DN100	885	CSL-335P-DN100	CSL-334P-DN100	695	229	356	470	300	312	432	29	335P	334P	1360
DN125	1360	CSL-245P-DN125	CSL-244P-DN125	730	279	470	495	377	347	305	40	245P	244P	1500
DN125	1360	CSL-345P-DN125	CSL-344P-DN125	730	279	470	495	377	347	432	41	345P	344P	1870
DN150	1870	CSL-275P-DN150	CSL-274P-DN150	755	305	470	521	377	365	305	50	275P	274P	1870
DN150	1870	CSL-375P-DN150	CSL-374P-DN150	755	305	470	521	377	365	432	51	375P	374P	2550
DN200	3060	CSL-377P-DN200	CSL-376P-DN200	991	356	572	648	484	464	432	83	377P	376P	3105
DN250	4930	CSL-385P-DN250	CSL-384P-DN250	1156	406	686	864	560	598	432	115	385P	384P	5610
DN300	7990	CSL-485P-DN300	CSL-484P-DN300	1156	406	686	864	560	642	610	125	485P	484P	8000
DN250	4930	CSL-685P-DN250	CSL-384P(2)-DN250*	1480	406	686	1143	560	820	787	171	685P	384P (2)*	11220
DN300	8415	CSL-685P-DN300	CSL-384P(2)-DN300*	1480	406	686	1143	560	820	787	171	685P	384P (2)*	11220
DN300	8415	CSL-485P(2)-DN300*	CSL-484P(2)-DN300*	1785	406	686	1448	560	547	610	209	485P (2)*	484P (2)*	16000

See Vacuum Filter Technical Data for sizing guidelines. *Denotes 2 elements stacked in housing.

PN10 Pattern Flange	Dimensions - mm			No. of Holes	Flange Thickness mm
	O.D.	B.C.	B.H.		
DN80	200	160	18	8	20
DN100	220	180	18	8	22
DN125	250	210	18	8	22
DN150	285	240	22	8	22
DN200	340	295	22	8	24
DN250	395	350	22	12	26
DN300	445	400	22	12	26

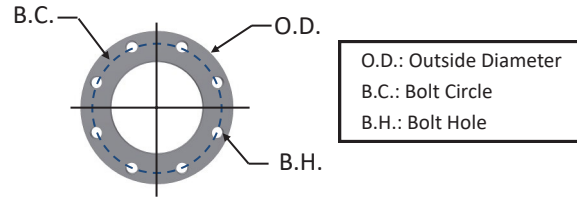

All flanges are orientated "split center".

BSPT Assemblies

BSPT Inlet & Outlet	Assembly m ³ /hr Rating	Assembly Part Number		Dimensions - mm						Suggested Service Ht. G	Approx. Weight kg	Replacement Element Part No.		Element m ³ /hr Rating
		Polyester	Paper	A	B	C	D	E	F			Polyester	Paper	
3"	510	CSL-235P-301	CSL-234P-301	695	229	356	470	300	312	305	21	235P	234P	970
3"	510	CSL-335P-301	CSL-334P-301	695	229	356	470	300	312	432	23	335P	334P	1360
4"	885	CSL-235P-401	CSL-234P-401	695	229	356	470	300	312	305	23	235P	234P	970
4"	885	CSL-335P-401	CSL-334P-401	695	229	356	470	300	312	432	25	335P	334P	1360
5"	1360	CSL-245P-501	CSL-244P-501	730	279	470	495	377	347	305	37	245P	244P	1500
5"	1360	CSL-345P-501	CSL-344P-501	730	279	470	495	377	347	432	40	345P	344P	1870
6"	1870	CSL-275P-601	CSL-274P-601	755	305	470	521	377	365	305	43	275P	274P	1870
6"	1870	CSL-375P-601	CSL-374P-601	755	305	470	521	377	365	432	44	375P	374P	2550

See Vacuum Filter Technical Data for sizing guidelines.



SOLBERG

All model offerings and design parameters are subject to change without prior notice.
Contact your representative or Solberg for the most current information.

Technical Data

Inlet Vacuum Filters

Applications & Equipment

- Industrial & Severe Duty
- Vacuum Pumps & Systems: Roots, Rotary Vane, Screw, Piston
- Vacuum Packaging Equipment
- Vacuum Furnace
- Blowers: Side Channel & P.D.
- Vacuum Lifters
- Intake Suction Filters
- Food Industry
- Woodworking/Routers
- Ash Handling
- Printing Industry
- Medical/Hospital
- Remote Installations for Piston & Screw Compressors
- Paper Processing
- Waste Water Aeration
- Cement Processing
- Bag House Systems
- Vacuum Vent Breathers
- Chemical Processing
- Factory Automation Equipment
- Leak Detection Systems

Identification

Standard Solberg assemblies should have an identification label/nameplate that gives the following information:

- Assembly Model #
- Replacement Element #

The part number designates the filter type, the element configuration and housing connection size. For example, the following part number identifies the filter as being a “CSL” design filter with a “235” element, “P” prefilter and DN100 flange connection size.

CSL-235P-DN100

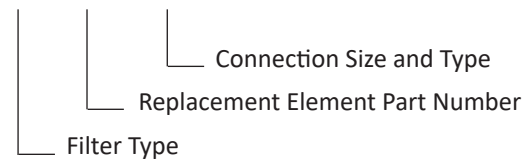

Vacuum Service Rating Chart

Threaded vacuum filter connections must be free of defect and properly sealed to achieve deeper vacuum levels. Vacuum service levels are given for reference only and serve as a guideline for product selection. Product certification and alternative designs are available for applications requiring deeper vacuum levels and specific leak rates. Please contact factory for details.

Vacuum Level	Pressure (mbar)	Pressure (Torr)	Pressure (Pa)
Atmospheric Pressure	1013	760	1.013x10 ⁵
Coarse Vacuum	1013 to 33	760 to 25	1x10 ⁵ to 3x10 ³
Medium Vacuum	33 to 1.3x10 ⁻³	25 to 1x10 ⁻³	3x10 ³ to 1x10 ⁻¹
High Vacuum	1.3x10 ⁻³ to 1.3x10 ⁻⁹	1x10 ⁻³ to 1x10 ⁻⁹	1x10 ⁻¹ to 1x10 ⁻⁷

Inlet Vacuum Filters

Choosing the Best Filter for Your Equipment

A. When the connection & airflow is known:

1. select the appropriate connection style. (i.e.: BSPT, Flange, BSPP, etc.)
2. check assembly m³/hr (flow) rating. Compare with your required airflow.

(Note: Assembly flow ratings are based on 6,000 FPM or 30m/sec for a given connection size to achieve low pressure drop performance. When required flow exceeds assembly flow rating, the pressure drop through the outlet connection will increase. In such cases select by element m³/hr (flow) rating.)

3. when required flow rating matches connection size; skip to "C. Selecting Elements".

B. When the connection size is unknown, flexible, or the required flow rating exceeds assembly flow rating:

1. match required flow rating with the element flow rating.
2. choose related connection size.

C. Selecting Elements: The filter performance is influenced by the actual application duty and the equipment it is installed on. Regular maintenance checks and proper servicing is required.

Application Duty Descriptions:

Industrial Duty: clean workshop or clean outdoor environment - small element sizing is sufficient.

Severe Duty: dirty workshop, wastewater – medium to large element is recommended.

Extreme Duty: cement, steel making, plastics or dusty material conveying – largest element sizing is recommended.

1. Select media required by your application. Options include:

a. Standard media

1. Polyester: all purpose; withstands pulses, moisture, and oily air
2. Paper: mostly dry, smooth flow applications

b. Special Media: for a variety of micron levels and media types, see the "Filter Media Specifications" in the Replacement Element Section or contact Solberg.

2. Select element size by matching the element with the anticipated duty and upsize accordingly.

Filter Assembly Maintenance

Request the appropriate maintenance manual for more in-depth information from your Solberg representative or on our website: www.solbergmfg.com.

Element Maintenance

Solberg elements should be replaced once the pressure drop reaches 37-50 mbar above the initial pressure drop of the installation. Cleaning the element is also an option.

Solberg recommends replacing dirty elements for optimal performance. Any damage which results from by-pass or additional pressure drop created by element cleaning is the sole responsibility of the operator.

Note: The overall performance of a filter element is altered once cleaned. The initial pressure drop after subsequent cleanings will be greater than the original, clean pressure drop of the element. After each cleaning, the pressure drop will continue to increase. Under all circumstances, the initial pressure drop of the element needs to be maintained at less than 37 mbar.

If the pressure drop exceeds 50 mbar at start-up; it should be replaced with a new element. With many types of equipment, the maximum pressure drop allowed will be dictated by the ability of the equipment to perform to its rated capacity. Under all circumstances, the operator should avoid exceeding the manufacturer's recommended maximum pressure drop for their specific equipment.



All model offerings and design parameters are subject to change without prior notice.
Contact your representative or Solberg for the most current information.